

Valceková jednoradova retaz DIN 8187 Eurovska seria B

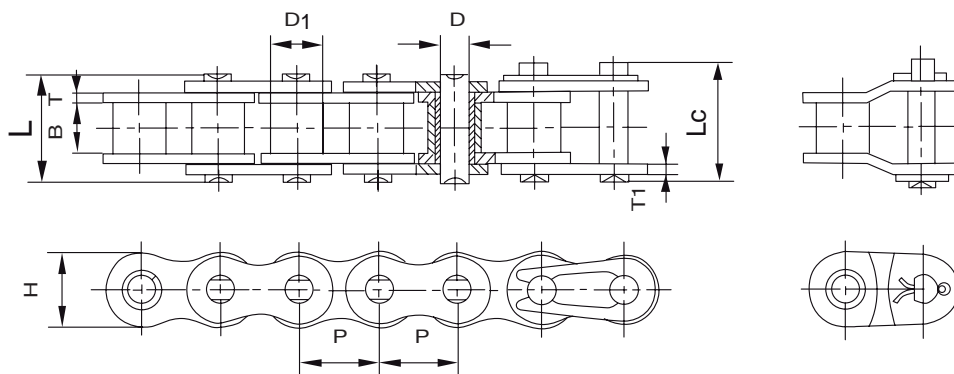

Referencia	Rozostup	Vnutorna sirka	Ø Valcek	Ø Cap	Dlzka capu		Vyska platnicky	Hrubka platnicky	Sila pri pretrhnuti	Hmotnost / meter
DIN/ISO	P	B min	D1 max	D max	L max	Lc max	H max	T/T1 max	Q min	q
	mm	mm	mm	mm	mm	mm	mm	mm	KN	Kg/m
04B-1	6,000	2,80	4,00	1,85	6,80	7,8	5,00	0,60	3,0	0,11
05B-1	8,000	3,00	5,00	2,31	8,20	8,9	7,10	0,80	5,0	0,20
*06B-1	9,525	5,72	6,35	3,28	13,15	14,1	8,20	1,30	9,0	0,41
08B-1	12,700	7,75	8,51	4,45	16,70	18,2	11,80	1,60	18,0	0,69
10B-1	15,875	9,65	10,16	5,08	19,50	20,9	14,70	1,70	22,4	0,93
12B-1	19,050	11,68	12,07	5,72	22,50	24,2	16,00	1,85	29,0	1,15
16B-1	25,400	17,02	15,88	8,28	36,10	37,4	21,00	4,15/3,1	60,0	2,71
20B-1	31,750	19,56	19,05	10,19	41,30	45,0	26,40	4,5/3,5	95,0	3,70
24B-1	38,100	25,40	25,40	14,63	53,40	57,8	33,20	6,0/4,8	160,0	7,10
28B-1	44,450	30,99	27,94	15,90	65,10	69,5	36,70	7,5/6,0	200,0	8,50
32B-1	50,800	30,99	29,21	17,81	66,00	71,0	42,00	7,0/6,0	250,0	10,25
40B-1	63,500	38,10	39,37	22,89	82,20	89,2	52,96	8,5/8,0	355,0	16,35
48B-1	76,200	45,72	48,26	29,24	99,10	107,0	63,80	12/10	560,0	25,00
56B-1	88,900	53,34	53,98	34,32	114,60	123,00	77,80	13,5/12,0	850,00	35,78
64B-1	101,600	60,96	63,50	39,40	130,00	138,50	90,17	15,0/13,0	1.100,00	46,00
72B-1	114,300	68,58	72,39	44,48	147,40	156,40	103,60	17,0/15,0	1.400,00	60,80

* Rovne platnicky

Valceková dvojradova retaz DIN 8187 Európska seria

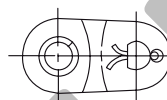
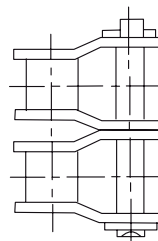
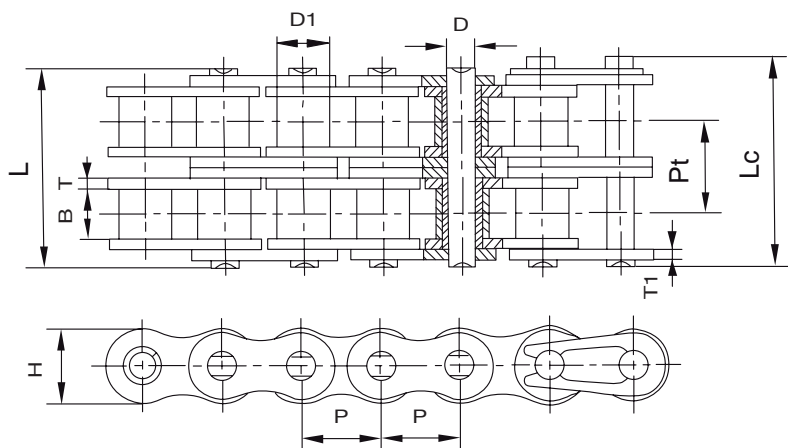

Referencia	Rozostup	Vnútorná sirka	Ø Valcek	Ø Cap	Dĺžka capu	Vyska platnický	Hrúbka platnický	Medziosova vzdialenosť	Sila pri pretrhnutí	Hmotnosť / meter	
DIN/ISO	P	B min	D1 max	D max	L max	Lc max	H max	T/T1 max	Pt	Q min	q
	mm	mm	mm	mm	mm	mm	mm	mm	mm	KN	Kg/m
05B-2	8,000	3,00	5,00	2,31	13,9	14,5	7,10	0,80	5,64	7,8	0,33
*06B-2	9,525	5,72	6,35	3,28	23,4	24,4	8,20	1,30	10,24	16,9	0,77
08B-2	12,700	7,75	8,51	4,45	31,2	32,2	11,80	1,60	13,92	32,0	1,34
10B-2	15,875	9,65	10,16	5,08	36,1	37,5	14,70	1,70	16,59	44,5	1,84
12B-2	19,050	11,68	12,07	5,72	42,0	43,6	16,00	1,85	19,46	57,8	2,31
16B-2	25,400	17,02	15,88	8,28	68,0	69,3	21,00	4,15/3,1	31,88	106,0	5,42
20B-2	31,750	19,56	19,05	10,19	77,8	81,5	26,40	4,5/3,5	36,45	170,0	7,20
24B-2	38,100	25,40	25,40	14,63	101,7	106,2	33,20	6,0/4,8	48,36	280,0	13,40
28B-2	44,450	30,99	27,94	15,90	124,6	129,1	36,70	7,5/6,0	59,56	360,0	16,60
32B-2	50,800	30,99	29,21	17,81	124,6	129,6	42,00	7,0/6,0	58,55	450,0	21,00
40B-2	63,500	38,10	39,37	22,89	154,5	161,5	52,96	8,5/8,0	72,29	630,0	32,00
48B-2	76,200	45,72	48,26	29,24	190,4	198,2	63,80	12/10	91,21	1.000,0	50,00
56B-2	88,900	53,34	53,98	34,32	221,20	229,60	77,80	13,5/12,0	106,60	1.600,00	71,48
64B-2	101,600	60,96	63,50	39,40	249,90	258,40	90,17	15,0/13,0	119,89	2.000,00	91,00
72B-2	114,300	68,58	72,39	44,48	283,70	292,70	103,60	17,0/15,0	136,27	2.500,00	120,40

* Rovne platnický

Valceková trojradová retaz DIN 8187 Evropska seria B

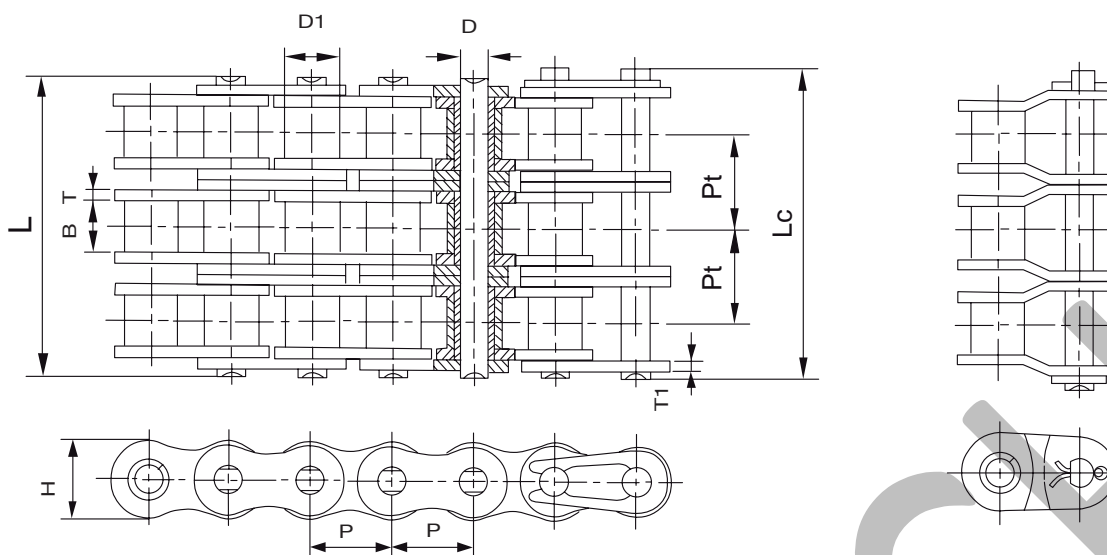

Referencia	Rozstup	Vnutorna sirka	Ø Valcek	Ø Cap	Dlžka capu	Vyska platnicky	Hrubka platnicky	Medziosova vzdialenost	Sila pri pretrhnuti	Hmotnost / meter	
DIN/ISO	P	B min	D1 max	D max	L max	Lc max	H max	T/T1 max	Pt	Q min	q
	mm	mm	mm	mm	mm	mm	mm	mm	mm	KN	Kg/m
05B-3	8,000	3,00	5,00	2,31	19,5	20,2	7,10	0,80	5,64	11,1	0,48
*06B-3	9,525	5,72	6,35	3,28	33,5	34,6	8,20	1,30	10,24	24,9	1,16
08B-3	12,700	7,75	8,51	4,45	45,1	46,1	11,80	1,60	13,92	47,5	2,03
10B-3	15,875	9,65	10,16	5,08	52,7	54,1	14,70	1,70	16,59	66,7	2,77
12B-3	19,050	11,68	12,07	5,72	61,5	63,1	16,00	1,85	19,46	86,7	3,46
16B-3	25,400	17,02	15,88	8,28	99,8	101,2	21,00	4,15/3,1	31,88	160,0	8,13
20B-3	31,750	19,56	19,05	10,19	114,2	117,9	26,40	4,5/3,5	36,45	250,0	10,82
24B-3	38,100	25,40	25,40	14,63	150,1	154,6	33,20	6,0/4,8	48,36	425,0	20,10
28B-3	44,450	30,99	27,94	15,90	184,2	188,7	36,70	7,5/6,0	59,56	530,0	24,92
32B-3	50,800	30,99	29,21	17,81	183,2	188,2	42,00	7,0/6,0	58,55	670,0	31,56
40B-3	63,500	38,10	39,37	22,89	226,8	233,8	52,96	8,5/8,0	72,29	950,0	48,10
48B-3	76,200	45,72	48,26	29,24	281,6	289,4	63,80	12/10	91,21	1.500,0	75,00
56B-3	88,900	53,34	53,98	34,32	327,80	336,20	77,80	13,5/12,0	106,60	2.240,00	107,18
64B-3	101,600	60,96	63,50	39,40	369,80	378,30	90,17	15,0/13,0	119,89	3.000,00	136,00
72B-3	114,300	68,58	72,39	44,48	420,00	429,00	103,60	17,0/15,0	136,27	3.750,00	180,00

* Rovne platnicky